

NATURAL SCIENCES
ADMISSIONS ASSESSMENT

D568/12

Specimen Sample Questions – Updated for 2022

30 minutes

SECTION 2

This paper contains a reduced number of sample questions. In the full paper, there are 20 questions in each part, and the time to complete the paper is 60 minutes.

INSTRUCTIONS TO CANDIDATES

Please read these instructions carefully, but do not open this question paper until you are told that you may do so. This paper is Section 2 of 2.

A separate answer sheet is provided for this paper. Please check you have one. You also require a soft pencil and an eraser.

Please complete the answer sheet with your candidate number, centre number, date of birth, and name.

This paper contains **three** parts: **X**, **Y** and **Z**.

All candidates should complete only **one** part chosen from:

Part X	Physics
Part Y	Chemistry
Part Z	Biology

Each part has 10 multiple-choice questions. There are no penalties for incorrect responses, only marks for correct answers, so you should attempt **all** 10 questions in your chosen part. Each question is worth one mark.

For each question, choose the **one** option you consider correct and record your choice on the separate answer sheet. If you make a mistake, erase thoroughly and try again.

You **must** complete the answer sheet within the time limit.

You can use the question paper for rough working, but **no extra paper** is allowed. Only your responses on the answer sheet will be marked.

A Periodic Table is included.

Dictionaries and calculators are NOT permitted.

Please wait to be told you may begin before turning this page.

This question paper consists of 37 printed pages and 7 blank pages.

BLANK PAGE

Paper content

Periodic Table.....	5
Part X Physics.....	7
Part Y Chemistry.....	19
Part Z Biology.....	31

BLANK PAGE

H 1																	He 2
Li 3	Be 4															F 9	Ne 10
Na 11	Mg 12															Cl 17	Ar 18
K 19	Ca 20	Sc 21	Ti 22	V 23	Cr 24	Mn 25	Fe 26	Co 27	Ni 28	Cu 29	Zn 30	Ga 31	Ge 32	As 33	Se 34	Br 35	Kr 36
Rb 37	Sr 38	Y 39	Zr 40	Nb 41	Mo 42	Tc 43	Ru 44	Rh 45	Pd 46	Ag 47	Cd 48	In 49	Sn 50	Sb 51	Te 52	I 53	Xe 54
Cs 55	Ba 56	<i>Lanthanoids</i> 57-71		Ta 73	W 74	Re 75	Os 76	Ir 77	Pt 78	Au 79	Hg 80	Tl 81	Pb 82	Bi 83	Po 84	At 85	Rn 86
Fr 87	Ra 88	<i>Actinoids</i> 89-103		Db 105	Sg 106	Bh 107	Hs 108	Mt 109	Ds 110	Rg 111	Cn 112	Nh 113	Fl 114	Mc 115	Lv 116	Ts 117	Og 118

symbol atomic number

Lanthanoids	La 57	Ce 58	Pr 59	Nd 60	Pm 61	Sm 62	Eu 63	Gd 64	Tb 65	Dy 66	Ho 67	Er 68	Tm 69	Yb 70	Lu 71
Actinoids	Ac 89	Th 90	Pa 91	U 92	Np 93	Pu 94	Am 95	Cm 96	Bk 97	Cf 98	Es 99	Fm 100	Md 101	No 102	Lr 103

BLANK PAGE

Part X Physics

- 1 A ball is thrown horizontally with velocity v from a height of 4 m vertically above a point Q that is on horizontal ground.

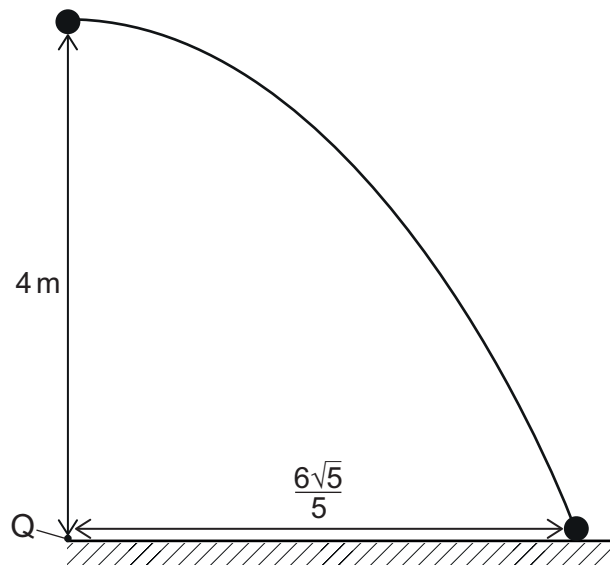

The ball hits the ground at a distance of $\frac{6\sqrt{5}}{5}$ m from Q.

What is the value of v ?

(gravitational field strength = 10 N kg^{-1} ; air resistance is negligible)

- A $\frac{3}{5} \text{ m s}^{-1}$
- B $\frac{3}{\sqrt{5}} \text{ m s}^{-1}$
- C 3 m s^{-1}
- D $3\sqrt{2} \text{ m s}^{-1}$
- E $3\sqrt{5} \text{ m s}^{-1}$

- 2 A wire of length 4.0 m with a uniform cross-sectional area of 0.020 mm^2 is connected in series with a $1.0 \text{ k}\Omega$ resistor.

There is a pd of 1.2 V across this arrangement and a voltmeter connected across the $1.0 \text{ k}\Omega$ resistor reads 1.0 V.

Under these conditions, what is the resistivity of the material from which the wire is made?

- A $1.0 \times 10^{-6} \Omega \text{ m}$
- B $1.1 \times 10^{-5} \Omega \text{ m}$
- C $1.0 \times 10^{-3} \Omega \text{ m}$
- D $1.1 \times 10^{-2} \Omega \text{ m}$
- E $8.0 \times 10^{-2} \Omega \text{ m}$
- F $8.0 \times 10^2 \Omega \text{ m}$
- G $4.0 \times 10^7 \Omega \text{ m}$
- H $4.0 \times 10^{10} \Omega \text{ m}$

- 3 The circuit shown includes a battery with an emf of 20V and an ideal ammeter. The reading on the ammeter is 2.0A.

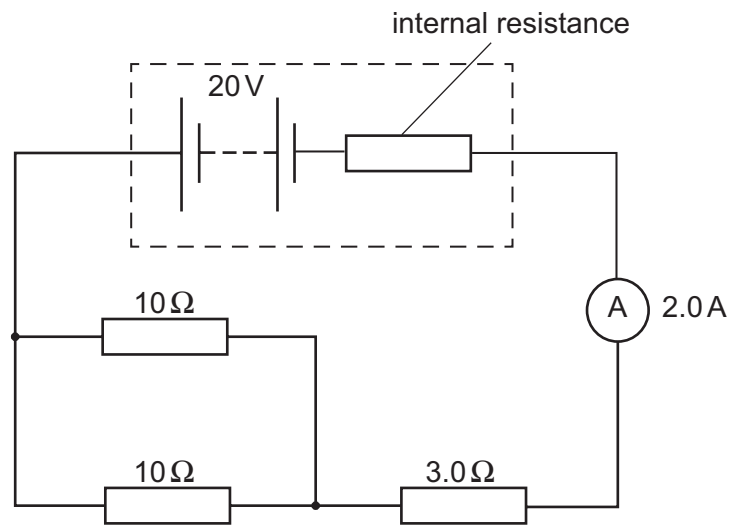

What is the internal resistance of the battery?

- A $2.0\ \Omega$
- B $4.0\ \Omega$
- C $7.0\ \Omega$
- D $10\ \Omega$
- E $18\ \Omega$

- 4 A heavy boulder is being dragged across a rough horizontal surface at constant velocity of 0.20 m s^{-1} by four steel cables connected in parallel with one another. Each cable has a cross-sectional area of 2.0 cm^2 and is under a constant elastic strain of 0.0025

What is the total power being transferred by the cables?

(Young modulus of steel = $2.0 \times 10^{11} \text{ Pa}$)

- A 20 kW
- B 25 kW
- C 80 kW
- D 100 kW
- E 400 kW
- F 800 MW
- G 1.0 GW
- H 4.0 GW

- 5 An object of mass m moving through air experiences an air resistance (drag) force F given by

$$F = kv^n$$

where k and n are positive constants.

The object is released from rest from a great height and falls vertically. No horizontal forces act on the object.

When it is travelling at a speed of v_0 , its acceleration is 50% of the acceleration of free fall.

What is the terminal speed of the object?

- A $2^n v_0$
- B $2^{(1/n)} v_0$
- C $2v_0$
- D $2^{-n} v_0$
- E $2^{-1} v_0$
- F $2^{-(1/n)} v_0$

- 6** Two identical springs each have an unstretched length of 12.0 cm, a spring constant k and negligible mass.

One spring is hung from a fixed point. A 100g mass is hung from the lower end of the spring.

The second spring is attached to the base of the 100g mass. A second 100g mass is hung from the lower end of this second spring.

The combined length of the two springs (not including the heights of the masses) is now 30.0 cm. Neither spring exceeds its elastic limit.

What is the spring constant k ?

(gravitational field strength = 10 Nkg^{-1})

- A** 0.10 Ncm^{-1}
- B** 0.17 Ncm^{-1}
- C** 0.25 Ncm^{-1}
- D** 0.33 Ncm^{-1}
- E** 0.50 Ncm^{-1}
- F** 0.67 Ncm^{-1}
- G** 1.0 Ncm^{-1}

- 7 A ray of light in air strikes the surface of a rectangular transparent block at an angle of 60° to the normal. The ray passes through the block and exits from the far side as shown. The width of the block is 5.0 cm and the distance between the normal at the point of entry to the block and the normal at the point of exit from the block is 2.5 cm.

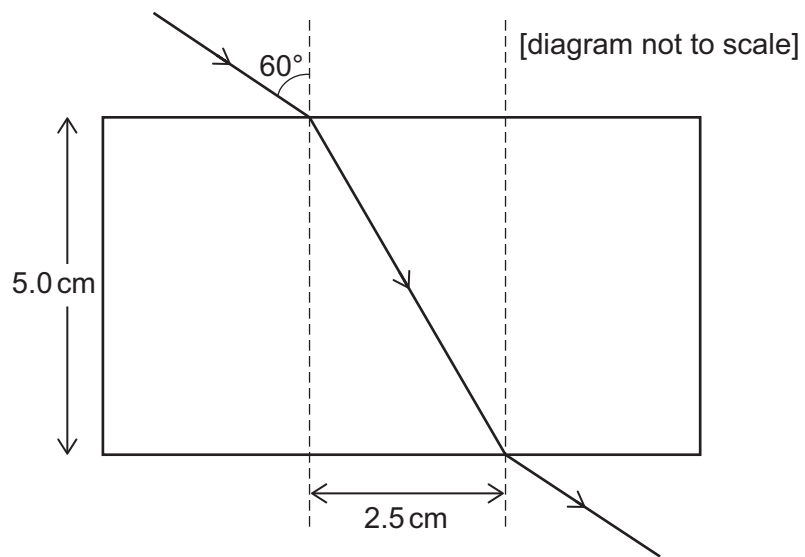

What is the refractive index of the block?

- A $\frac{2}{\sqrt{15}}$
 B $\frac{1}{\sqrt{3}}$
 C $\frac{1}{\sqrt{2}}$
 D $\frac{2}{\sqrt{5}}$
 E $\frac{\sqrt{5}}{2}$
 F $\sqrt{2}$
 G $\sqrt{3}$
 H $\frac{\sqrt{15}}{2}$

8 Two point masses, P and Q, are 60 m apart at time $t = 0$.

P has a constant acceleration of 6.0 ms^{-2} in the direction towards Q. At time $t = 0$, P has a velocity of zero.

Q has a constant acceleration of 2.0 ms^{-2} in the direction away from P. At time $t = 0$, Q has a velocity of 14 ms^{-1} towards P.

At what time do the masses meet?

- A 2.5 s
- B 3.0 s
- C 3.5 s
- D 6.0 s
- E 6.5 s
- F 7.0 s
- G 10 s

- 9 An electric circuit contains two different power supplies with negligible internal resistance, three identical resistors, an ideal ammeter and an ideal voltmeter.

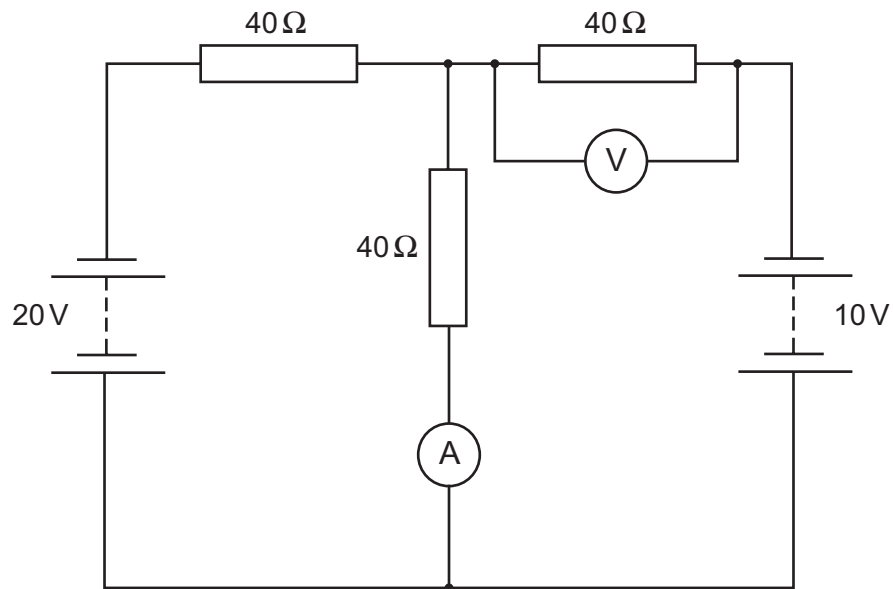

What are the readings on the ammeter and the voltmeter?

	<i>ammeter reading</i>	<i>voltmeter reading</i>
A	0.25 A	0 V
B	0.50 A	0 V
C	0.75 A	0 V
D	0.25 A	10 V
E	0.50 A	10 V
F	0.75 A	10 V

- 10** Water at the top of a waterfall has zero vertical velocity. The water falls 45 m vertically onto a flat horizontal rock of area 2.0 m^2 .

Each second, 40 kg of water hits the rock.

When the water hits the rock it flows away horizontally.

At any instant the average depth of water on the rock surface is 0.050 m.

What is the total average pressure on the rock due to water?

(gravitational field strength = 10 N kg^{-1} ; density of water = 1000 kg m^{-3} ; assume air resistance is negligible)

- A** 400 Pa
- B** 500 Pa
- C** 600 Pa
- D** 1000 Pa
- E** 1100 Pa
- F** 1200 Pa
- G** 1700 Pa
- H** 2200 Pa

BLANK PAGE

Part Y Chemistry

- 11 A methane gas burner heats objects with only 20% efficiency.

The gas burner is used to heat a 500 g copper pan containing 400 g water from 20 °C to 80 °C.

specific heat capacities: copper = $0.4 \text{ J g}^{-1} \text{ °C}^{-1}$; water = $4 \text{ J g}^{-1} \text{ °C}^{-1}$

standard enthalpy change of combustion of methane = -900 kJ mol^{-1}

What is the minimum mass of methane gas required?

(M_r value: methane = 16)

- A 1.92 g
- B 2.40 g
- C 8.53 g
- D 9.60 g
- E 11.4 g
- F 12.8 g
- G 21.12 g

- 12** Mercury(II) fulminate, $\text{HgC}_2\text{N}_2\text{O}_2$, can decompose to produce carbon monoxide and two different elements only.

The enthalpy change for the decomposition of one mole of mercury(II) fulminate is -606 kJ .

The enthalpy change of formation for mercury(II) fulminate is $+386 \text{ kJ mol}^{-1}$.

What is the enthalpy change of formation of carbon monoxide?

(Assume that all data is given at the same temperature and pressure.)

- A** -110 kJ mol^{-1}
- B** $+110 \text{ kJ mol}^{-1}$
- C** -166 kJ mol^{-1}
- D** $+166 \text{ kJ mol}^{-1}$
- E** -220 kJ mol^{-1}
- F** $+220 \text{ kJ mol}^{-1}$
- G** -496 kJ mol^{-1}
- H** $+496 \text{ kJ mol}^{-1}$

- 13 The mass spectrum of a hydrocarbon, X, is shown.

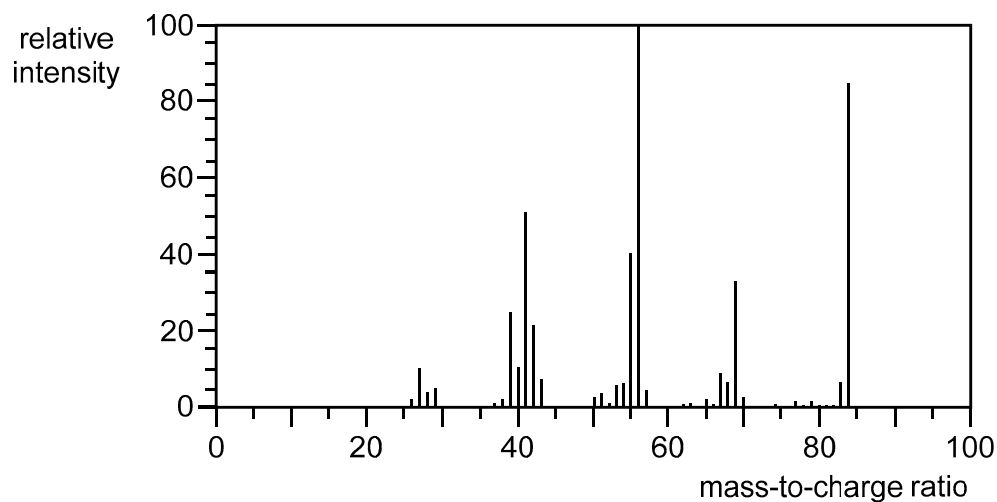

X contains 14.3% by mass of hydrogen and does **not** decolourise aqueous bromine.

Which of the following could be the identity of X?

- 1 hex-2-ene
- 2 cyclohexane
- 3 cyclobutane

(A_r values: H = 1; C = 12)

- A 1 only
- B 2 only
- C 3 only
- D 1 and 2 only
- E 1 and 3 only
- F 2 and 3 only

- 14** Thionyl chloride, SOCl_2 , is the only product of the reaction between sulfur trioxide, chlorine and sulfur dichloride.

Thionyl chloride reacts with water to make hydrogen chloride and one other gaseous product, which is triatomic.

2.0 dm^3 of chlorine gas (measured at room temperature and pressure) was reacted completely with sulfur trioxide and sulfur dichloride.

The product was isolated, dissolved in water and made up to 200 cm^3 .

What is the maximum concentration of HCl in the resulting solution?

(Assume that one mole of gas at room temperature and pressure occupies 24 dm^3 .)

- A** 0.28 mol dm^{-3}
- B** 0.50 mol dm^{-3}
- C** 0.83 mol dm^{-3}
- D** 1.25 mol dm^{-3}
- E** 2.50 mol dm^{-3}
- F** 5.00 mol dm^{-3}

- 15 Tollens' reagent, $[\text{Ag}(\text{NH}_3)_2]\text{NO}_3(\text{aq})$, can be used to coat glass surfaces with silver metal ($A_r = 108$) to make decorative objects. It is a reducing agent and reacts by oxidising aldehydes to carboxylic acids.

The half-equation for the organic oxidation can be represented as (R = alkyl group):

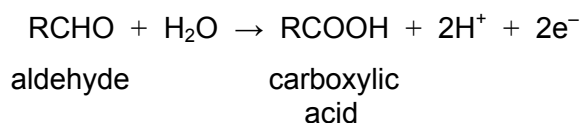

All of the inside surface of a beaker is to be coated in a uniform layer of silver metal of thickness 0.01 cm. The beaker can be modelled as a cylinder of height 10 cm and radius 5 cm.

The density of silver metal is 10.5 g cm^{-3} .

Which of the following expressions gives the minimum number of moles of aldehyde required?

(Assume that the yield of any reaction is 100%.)

- A $\frac{10.5 \times 1.25 \times \pi}{2 \times 108}$
- B $\frac{10.5 \times 1.25 \times \pi}{108}$
- C $\frac{2 \times 10.5 \times 1.25 \times \pi}{108}$
- D $\frac{108 \times 10.5 \times 1.25 \times \pi}{2}$
- E $\frac{10.5 \times 1.5 \times \pi}{2 \times 108}$
- F $\frac{2 \times 10.5 \times 1.5 \times \pi}{108}$
- G $\frac{10.5 \times 1.5 \times \pi}{108}$
- H $\frac{108 \times 10.5 \times 1.5 \times \pi}{2}$

16 The following information should be used in calculating the answer to this question:

- Standard enthalpy change of formation of ethanol:

$$\Delta_f H^\circ(\text{CH}_3\text{CH}_2\text{OH(l)}) = -277 \text{ kJ mol}^{-1}$$

- Standard enthalpy change of vaporisation of ethanol, $\text{CH}_3\text{CH}_2\text{OH(l)} \rightarrow \text{CH}_3\text{CH}_2\text{OH(g)}$:

$$\Delta_{\text{vap}} H^\circ(\text{CH}_3\text{CH}_2\text{OH(l)}) = +39 \text{ kJ mol}^{-1}$$

- Standard enthalpy change of atomisation of carbon, $\text{C(s)} \rightarrow \text{C(g)}$:

$$\Delta_{\text{at}} H^\circ(\text{C(s)}) = +715 \text{ kJ mol}^{-1}$$

The table provides some average bond enthalpy data:

<i>bond</i>	C–C	C–O	H–H	O–H	O=O
<i>average bond enthalpy / kJ mol⁻¹</i>	346	358	436	463	498

Using the data provided, which of the following is the average bond enthalpy of the C–H bond?

- A 342 kJ mol⁻¹
- B 412 kJ mol⁻¹
- C 417 kJ mol⁻¹
- D 419 kJ mol⁻¹
- E 461 kJ mol⁻¹
- F 481 kJ mol⁻¹
- G 483 kJ mol⁻¹
- H 673 kJ mol⁻¹

- 17 In 1836, James Marsh devised a test to allow the detection of very small traces of arsenic.

The first stage of the Marsh test involves the reaction of arsenic trioxide, As_2O_3 , with zinc under acidic conditions. One of the products is compound X.

The **unbalanced** equation for the reaction is:

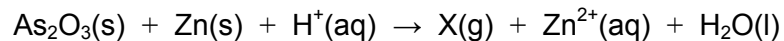

In the **balanced** equation, 1.0 mol of arsenic trioxide reacts with 6.0 mol of zinc, and produces 2.0 mol of X and 6.0 mol of zinc ions. Only the zinc and the arsenic change oxidation state in this reaction.

If 1.98 g of arsenic trioxide reacts with an excess of zinc and acid in this reaction, what is the maximum mass of X that could be produced?

(A_r values: H = 1; O = 16; Zn = 65; As = 75)

- A 0.39 g
- B 0.75 g
- C 0.78 g
- D 1.50 g
- E 1.56 g
- F 1.66 g

- 18 Compound P, with molecular formula C_5H_{10} , reacts with hydrogen bromide in an addition reaction to form compound Q as the major product.

Q undergoes a substitution reaction with aqueous sodium hydroxide to form compound R.

After R is completely oxidised using acidified potassium dichromate(VI), the resulting product does **not** react with aqueous sodium carbonate.

R undergoes an elimination reaction to form a mixture of products: P and S.

S has no stereoisomers.

What is compound P?

- A pent-1-ene
- B pent-2-ene
- C 2-methylbut-1-ene
- D 2-methylbut-2-ene
- E 3-methylbut-1-ene

- 19** Bromine trifluoride, BrF_3 , is a simple molecular compound containing single bonds only.

It is **not** trigonal planar.

Two of the bond lengths in this molecule are 0.181 nm, and the third is 0.172 nm.

The through-space distances between two fluorine atoms are 0.241 nm or 0.361 nm.

What is the acute bond angle in BrF_3 ?

A $\sin^{-1}\left(\frac{0.1205}{0.172}\right)$

B $\cos^{-1}\left(\frac{0.1205}{0.172}\right)$

C $\sin^{-1}\left(\frac{0.1205}{0.181}\right)$

D $\cos^{-1}\left(\frac{0.1205}{0.181}\right)$

E $\sin^{-1}\left(\frac{0.172}{0.1805}\right)$

F $\cos^{-1}\left(\frac{0.172}{0.1805}\right)$

G $\sin^{-1}\left(\frac{0.1805}{0.181}\right)$

H $\cos^{-1}\left(\frac{0.1805}{0.181}\right)$

- 20** Ethanoic acid, ethanol and water were added to a reaction vessel and a quantity of concentrated sulfuric acid was added. The reaction mixture was then heated and an ester (ethyl ethanoate) and water were formed in equilibrium with the reactants.

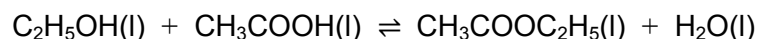

120 g of ethanoic acid and 92 g of ethanol were used and the mass of water present at the start of the experiment was 18 g. Assume that there is no change in volume.

At the temperature of the reaction, the equilibrium constant K_c is 2.00.

What is the mass of the ester present in the mixture at equilibrium?

(M_r values: ethanoic acid = 60; ethanol = 46; water = 18; ethyl ethanoate = 88)

- A** 1.00 g
- B** 53.0 g
- C** 88.0 g
- D** 103 g
- E** 106 g
- F** 176 g
- G** 209 g
- H** 215 g

BLANK PAGE

Part Z Biology

- 21** Stearic acid is a fatty acid. It contains 18 carbon atoms and zero carbon–carbon double bonds.

It can be represented by the notation C18:0, where 18 is the number of carbons and 0 is the number of carbon–carbon double bonds present.

The table shows this notation for two other fatty acids:

<i>fatty acid</i>	<i>notation</i>
oleic	C18:1
linoleic	C18:2

A triglyceride was formed using one of each of the three fatty acids.

Which statement about this triglyceride is correct?

- A** Linoleic acid is the most saturated fatty acid used to form the triglyceride.
- B** In the triglyceride, the stearic acid chain has 36 atoms of hydrogen.
- C** All the hydrocarbon chains in the triglyceride have a terminal carboxyl group.
- D** In the triglyceride, the three hydrocarbon chains would be the same length and parallel to each other.
- E** The triglyceride molecule has the same number of oxygen atoms as a molecule of glucose.

- 22** The ECG trace shows a recording of the electrical activity of the heart from a person who has a known cardiac condition.

The volume of blood pumped from the ventricles with each contraction was 70 cm^3 .

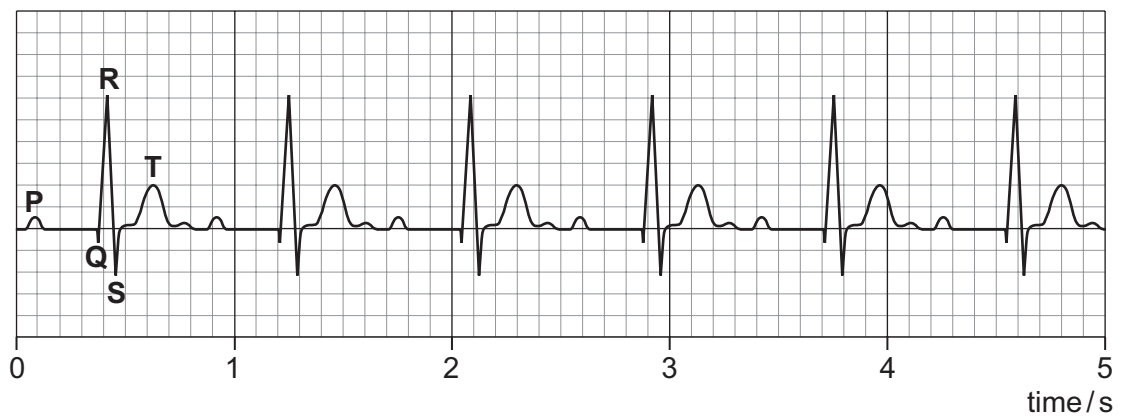

Which of the following statements is/are correct?

- 1** Cardiac output is 420 cm^3 per minute.
 - 2** There is an abnormal delay in conduction between the sinoatrial node (SAN) and the atrioventricular node (AVN).
 - 3** P indicates atrial diastole.
- A** none of them
- B** 1 only
- C** 2 only
- D** 3 only
- E** 1 and 2 only
- F** 1 and 3 only
- G** 2 and 3 only
- H** 1, 2 and 3

- 23 A student placed 5 cm long identical pieces of plant tissue into a range of different concentrations of salt solution. After one hour, the pieces were removed from the solutions and the length of each piece measured.

For each piece the initial length was divided by the final length, and these values were plotted on a graph against salt solution concentration.

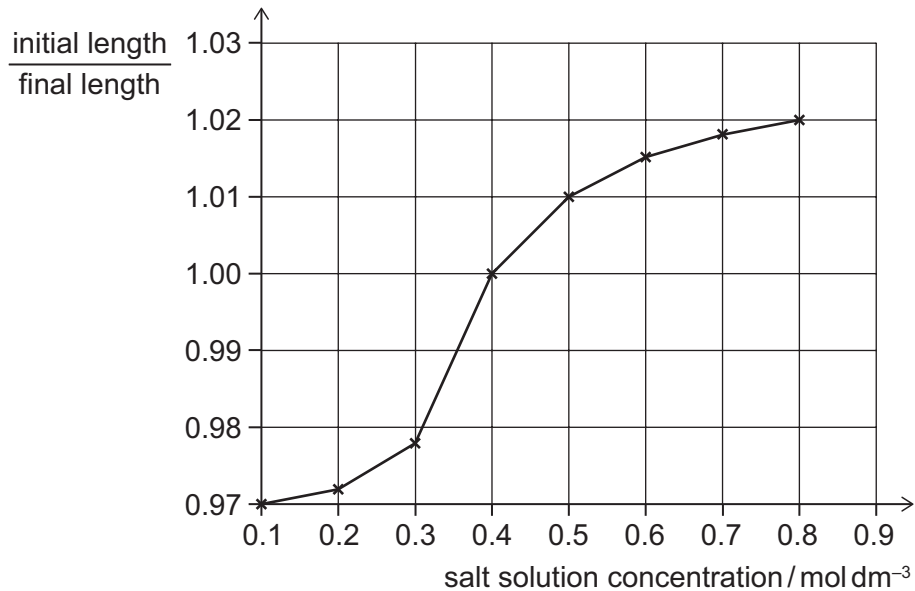

Which concentration of salt solution has the same water potential as the cell sap of the plant tissue, and what was the change in length, in mm, of the plant tissue placed in the 0.1 mol dm⁻³ salt solution?

	<i>concentration of salt solution with the same water potential as the cell sap / mol dm⁻³</i>	<i>change in length of plant tissue in 0.1 mol dm⁻³ salt solution / mm</i>
A	0.8	-0.15
B	0.8	-1.5
C	0.8	+1.5
D	0.4	-1.5
E	0.4	+0.15
F	0.4	+1.5
G	0.1	-0.15
H	0.1	+0.15

- 24 A study was carried out into the food sources of barn owls. Owls regurgitate the undigested remains of their prey as pellets. Analysis of these pellets was used to identify the food eaten by one owl, over a period of 2 weeks. The chart shows the number of animals in the owl's diet. The findings show that most of the owl's diet was mammals.

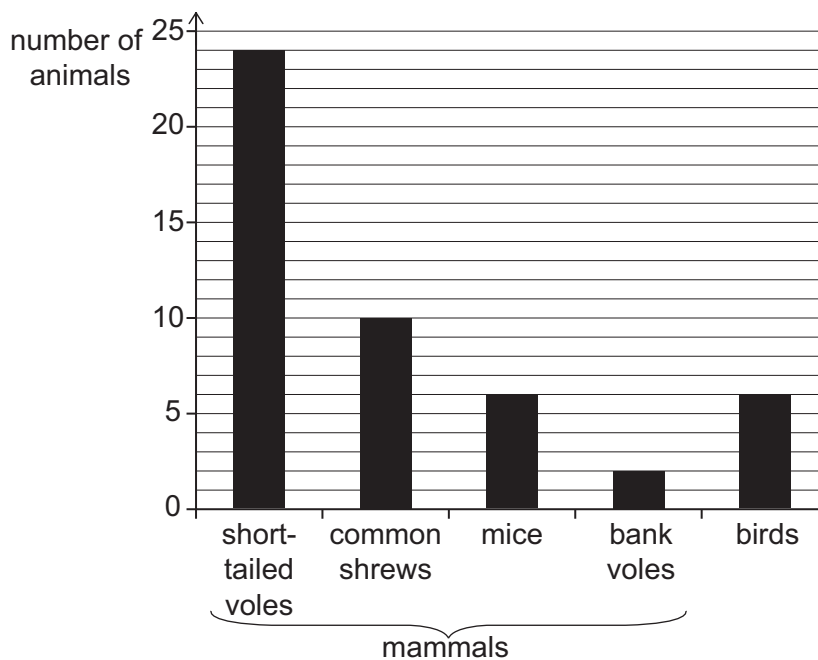

A second study was carried out over the following 2 weeks to find the change in the population of mice in the owl's habitat. The table shows the data obtained for the second study.

number of births	242
number of deaths	207
number joining from another population	11
number leaving to join another population	21

What is the percentage of mammals in the owl's diet that are mice in the first study, what is the mean change in the population of mice per week in the second study, and what can be concluded about the change in the number of mice in the owl's diet during the second study compared to the first study?

	<i>percentage of mammals that are mice in the owl's diet</i>	<i>mean change in the population of mice per week</i>	<i>conclusion about the change in the number of mice in the owl's diet</i>
A	12.5%	12.5	likely to increase
B	12.5%	25.0	likely to increase
C	12.5%	25.0	unlikely to increase
D	12.5%	45.0	insufficient evidence
E	14.3%	12.5	insufficient evidence
F	14.3%	12.5	unlikely to increase
G	14.3%	25.0	likely to increase
H	14.3%	45.0	unlikely to increase

- 25** The Tasmanian devil (*Sarcophilus harrisii*) is a carnivorous mammal with a diploid number of 14.

Three cells were removed from a healthy Tasmanian devil. The chromosomes in each cell were stained and are shown in the following diagram.

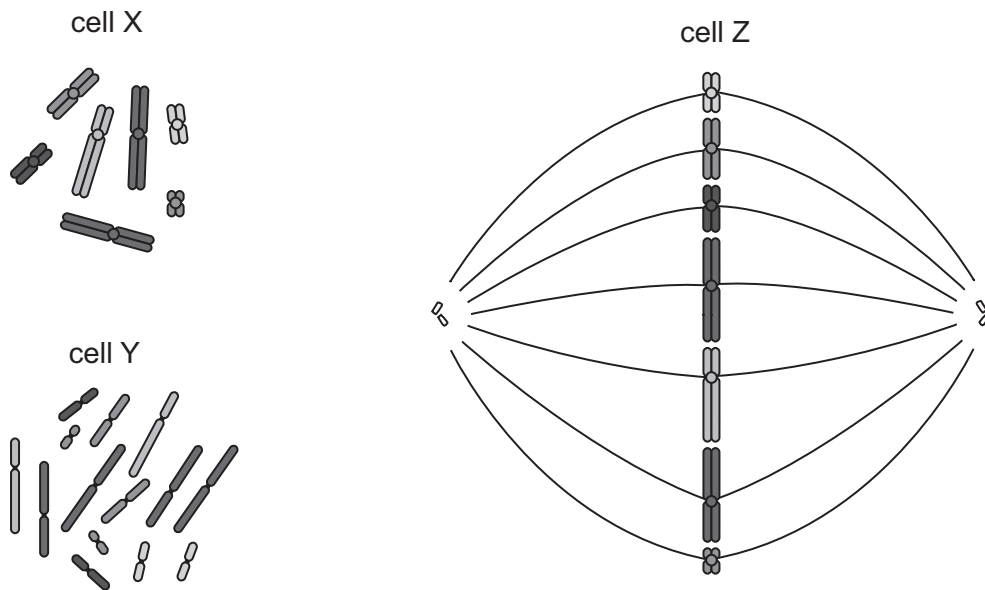

Which of the following statements is/are correct?

- 1 Cell X is the first stage of cell division after the end of interphase.
- 2 Cell Y has twice the mass of DNA as cell Z.
- 3 Cell Z is undergoing metaphase of mitosis.

(Assume no mutations.)

- A** none of them
- B** 1 only
- C** 2 only
- D** 3 only
- E** 1 and 2 only
- F** 1 and 3 only
- G** 2 and 3 only
- H** 1, 2 and 3

- 26** A student was investigating the vascular system in a flowering plant.

The student observed a photomicrograph showing a vascular bundle of this flowering plant, and identified features of a mature sieve tube element.

The cross-sectional area of a typical xylem vessel is six times greater than the cross-sectional area of this mature sieve tube element.

The cross-sectional area of a xylem vessel is $54\pi \mu\text{m}^2$.

Which row is correct for this mature sieve tube element?

(Assume that both cross-sectional areas are circular.)

	<i>outermost layer contains a structural polysaccharide</i>	<i>contains mitochondria</i>	<i>cross-sectional diameter of sieve tube element / μm</i>
A	yes	yes	3
B	yes	yes	6
C	yes	no	3
D	yes	no	6
E	no	yes	3
F	no	yes	6
G	no	no	3
H	no	no	6

- 27 The diagram shows apparatus that can be used to measure the water loss from a leafy shoot.

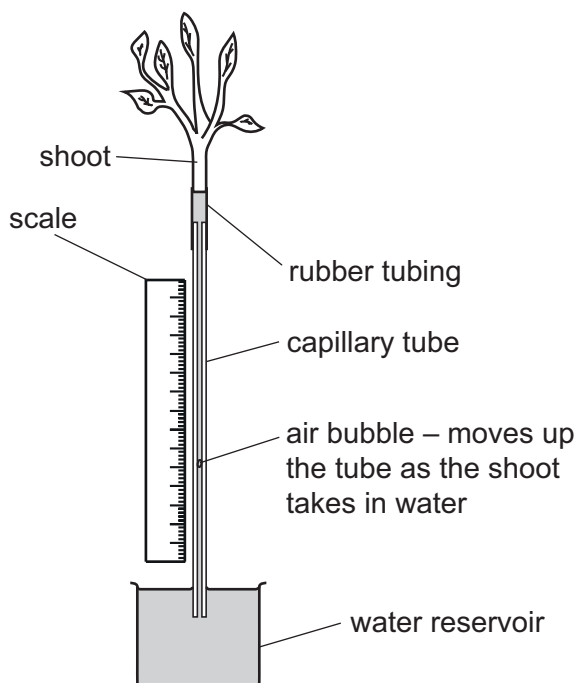

Three students, P, Q and R, each set up the apparatus and recorded how far the air bubble had moved in 15 minutes. It was observed that each student's apparatus had capillary tubing with a different internal diameter.

<i>student</i>	<i>distance bubble moved in 15 minutes / mm</i>	<i>internal diameter / mm</i>
P	90	0.60
Q	33	1.00
R	25	1.20

Which row shows the students' results from most water lost to least water lost, and what can be concluded about the observed results?

	<i>water lost from most to least</i>	<i>conclusion</i>
A	P Q R	the apparatus in P was placed in a humid environment
B	P Q R	there is insufficient information to explain the results
C	P R Q	the apparatus in P was placed in a hot dry environment
D	P R Q	there is insufficient information to explain the results
E	R Q P	the apparatus in R was placed in a humid environment
F	R Q P	there is insufficient information to explain the results
G	R P Q	the apparatus in R was placed in a hot dry environment
H	R P Q	there is insufficient information to explain the results

- 28** There is significant variation in the amount of oil present in maize grains.

In an experiment, maize grains were tested for their oil content and only those with either highest or lowest oil content were selected and planted. When this generation of plants matured and produced maize grains, these were tested for their oil content and the selection process was repeated. This was done over fifty generations of maize.

All plants were grown in the same conditions. The mean mass per maize grain was 0.4 g and did not change over the fifty generations. The results are shown in the graph.

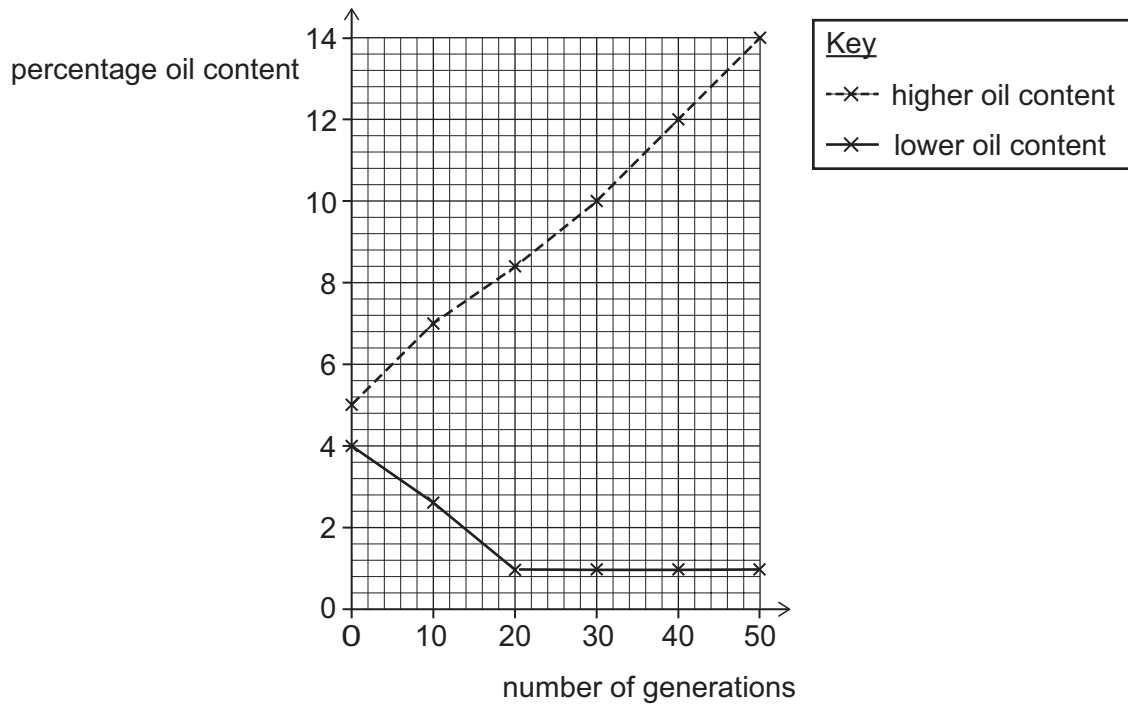

Which of the following statements about the experiment is/are correct?

- 1 The change in oil content over the fifty generations was due to natural selection.
 - 2 There was a 180% increase in the oil content of the grains with a higher oil content over the fifty generations.
 - 3 The change in mass of oil per grain in the higher oil content grains over the fifty generations was 0.036 g.
- A** none of them
B 1 only
C 2 only
D 3 only
E 1 and 2 only
F 1 and 3 only
G 2 and 3 only
H 1, 2 and 3

- 29** Pondweed, in a solution of sodium hydrogen carbonate, was placed in front of a light source to investigate the relationship between light intensity and the rate of photosynthesis. The number of bubbles of gas produced during a period of two minutes was recorded. The experiment was repeated with the light source at different distances from the pondweed.

The relationship between light intensity and distance (d) from a light source can be described

as: light intensity $\propto \frac{1}{d^2}$

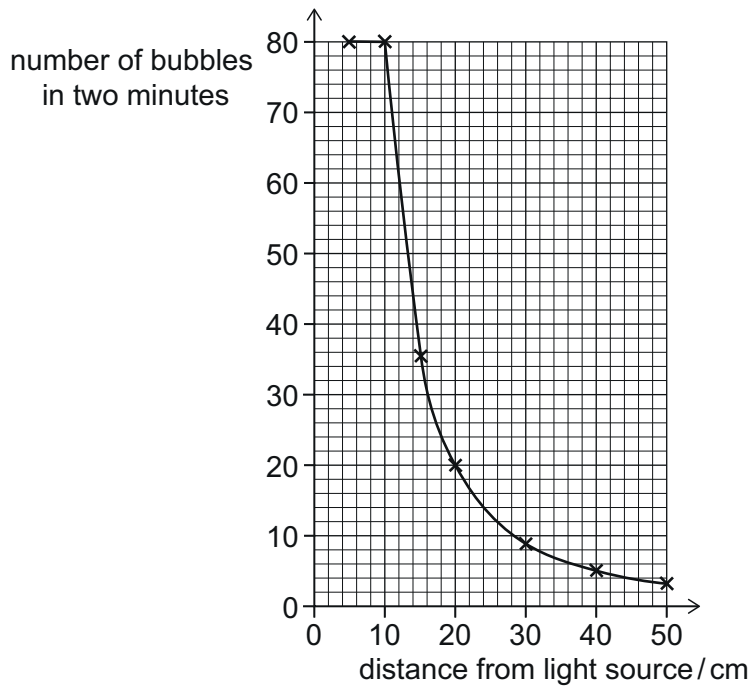

Which of the following statements is/are correct?

- 1 The bubbles produced were composed mostly of carbon dioxide.
 - 2 Between 10 cm and 50 cm the rate of photosynthesis is directly proportional to light intensity.
 - 3 At a distance of 5 cm from the pondweed, light intensity was the limiting factor for photosynthesis.
- A** none of them
- B** 1 only
- C** 2 only
- D** 3 only
- E** 1 and 2 only
- F** 1 and 3 only
- G** 2 and 3 only
- H** 1, 2 and 3

- 30** In flour beetles one gene controlling eye colour is located on chromosome 5. Flour beetles have two copies of chromosome 5 in each cell. One allele causes black eyes and a second allele causes red eyes.

The allele for black eye (B) is dominant over the allele for red eye (b).

$\frac{3}{4}$ of the **alleles** present in a population of 1600 flour beetles were the dominant B allele.

Which of the following statements is/are correct?

(Assuming that inheritance of the two alleles is a random process.)

- 1** The expected number of flour beetles with black eyes is 1500.
 - 2** The body cells of the flour beetles are diploid.
 - 3** The expected ratio of homozygous black eye beetles to heterozygous black eye beetles to red eye beetles will be 1 : 2 : 1
- A** none of them
- B** 1 only
- C** 2 only
- D** 3 only
- E** 1 and 2 only
- F** 1 and 3 only
- G** 2 and 3 only
- H** 1, 2 and 3

BLANK PAGE

BLANK PAGE



Cambridge Assessment
Admissions Testing